

# INSTALLATION MANUAL LADDERGUARD

4064 Peavey Rd. Chaska, MN 55318  
Toll Free: 866-933-2935  
www.safetypg.com

BY: Paul Boyum  
P/N: 100389

DATE: 30 November 2016

REVISION:

**C**

Page 1 of 6

## RECOMMENDED TOOLS FOR ASSEMBLY:

Two people are recommended for installation

Drill with 3/8" Drill Bit

Socket Set

Sharpie Marker or Equivalent

**LADDER GUARD ON  
FLAT IRON LADDER**

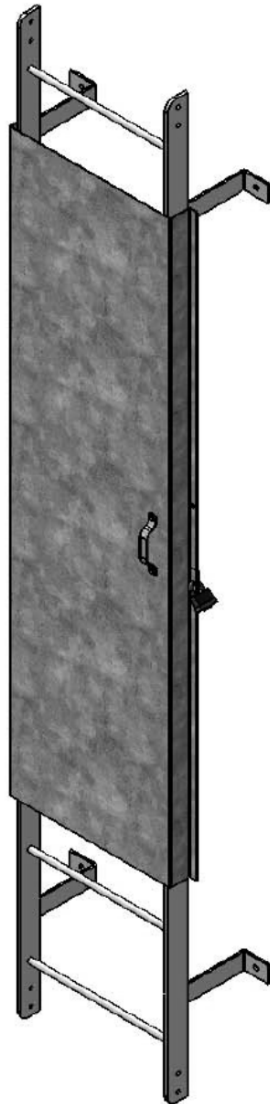

**LADDER GUARD ON  
ANGLE IRON LADDER**

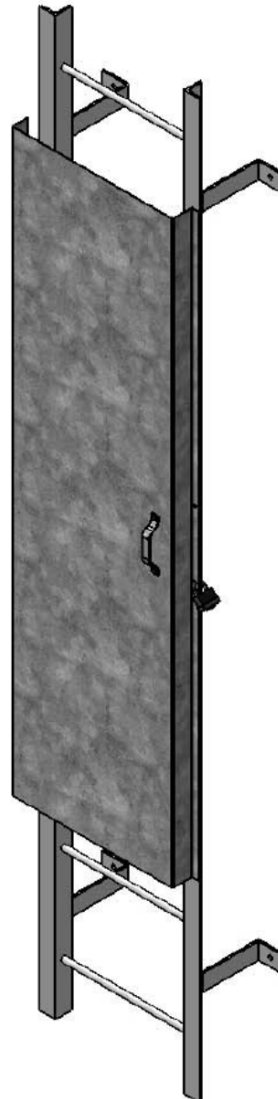

1. Align the handle onto the holes in the ladder guard.
2. Insert the hex bolts through the handle and door holes.

# INSTALLATION MANUAL LADDERGUARD

4064 Peavey Rd. Chaska, MN 55318  
Toll Free: 866-933-2935  
www.safetypg.com

BY: Paul Boyum  
P/N: 100389

DATE: 30 November 2016

REVISION:

**C**

Page 2 of 6

3. Fasten the nylock nuts onto the bolts, securing the handle to the door.

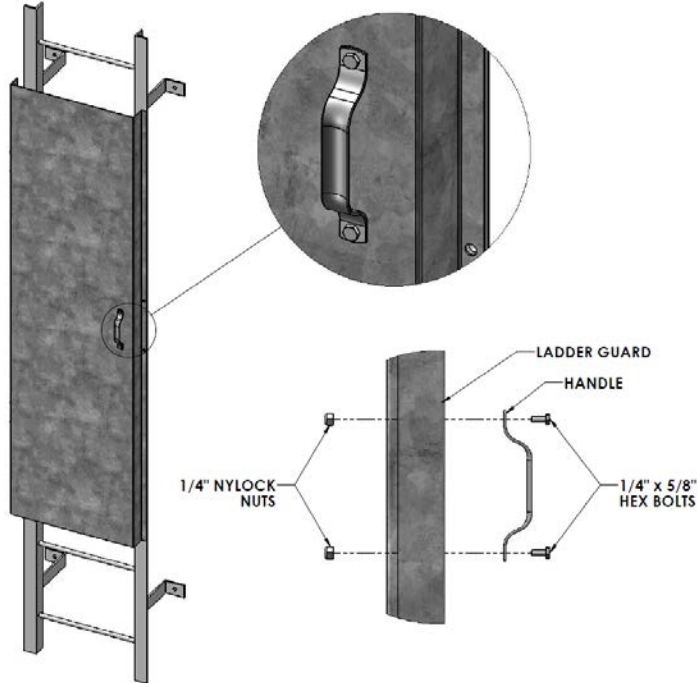

4. Align the hinges on the door with the ladder.
  - a. The recommended height to the bottom of the ladder from the ground is 24 inches.

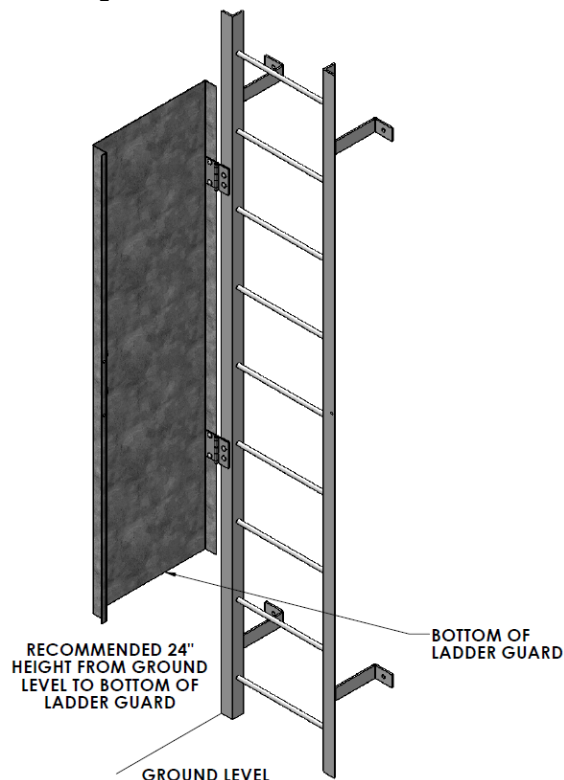

- b. The hinges should be parallel with the ladder rail.
    - c. The center of the hinge holes should be  $\frac{3}{4}$ " from the outside edge of the ladder rail.

5. Mark the hinge holes to be drilled into the ladder rail.

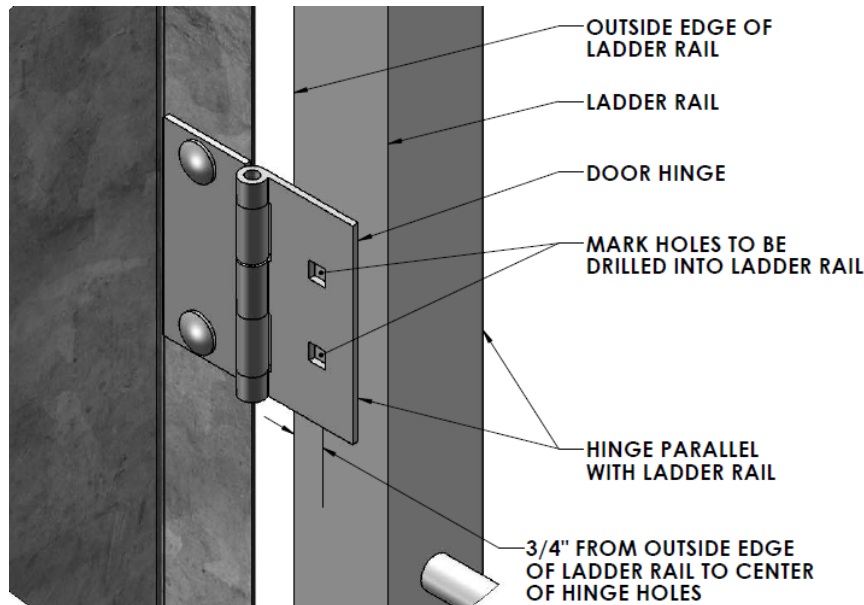

6. Drill the hinge holes into the ladder rail.
  - a. The appropriate drill size is 3/8".
7. Realign the ladder hinges with the drilled holes on the ladder rail.
8. Insert the carriage bolts through the door hinges.
9. Place the hinge spacers onto the bolts and against the door hinges.
10. Place the ladder guard against the ladder, ensuring that the carriage bolts pass through the drilled holes in the ladder rail.
11. Place the washers onto the carriage bolts.
12. Thread the nylock nuts onto the carriage bolts and secure the ladder guard to the ladder.

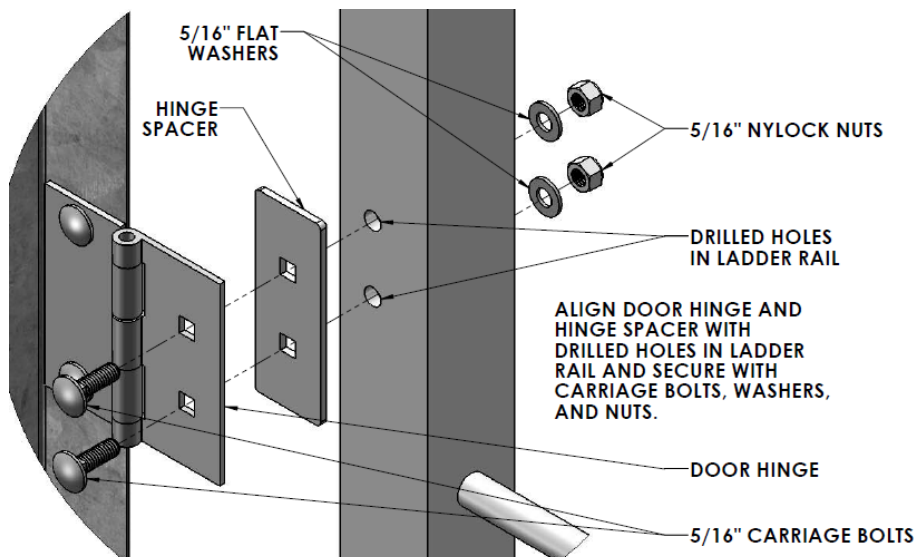

13. Close the ladder guard onto the ladder and check the closed alignment.
  - a. The closed edge of the ladder guard should be parallel with the ladder rail.

# INSTALLATION MANUAL LADDERGUARD

4064 Peavey Rd. Chaska, MN 55318  
Toll Free: 866-933-2935  
www.safetypg.com

BY: Paul Boyum  
P/N: 100389

DATE: 30 November 2016

REVISION:

C

Page 4 of 6

- i. Make any necessary adjustments before continuing.
14. There are two variations for securing the ladder guard to the ladder with a padlock.
  - a. Proceed to step 15 for angle iron ladders.
  - b. Proceed to step 16 for flat iron ladders.
15. For angle iron ladders:
  - a. With the ladder guard closed, mark the hole to be drilled for the padlock.

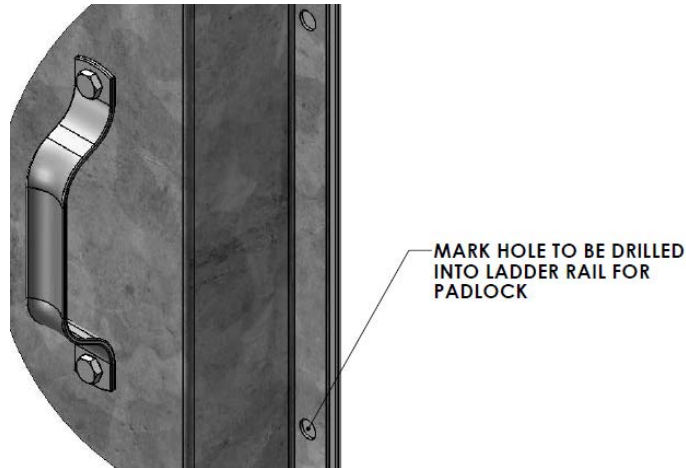

- b. Open the ladder guard and drill the padlock hole.
16. For flat iron ladders:
  - a. Close the ladder guard.
  - b. Place the padlock bracket into the gap between the ladder guard and ladder rail.
    - i. If there is a large space between the ladder and the Ladderguard proceed to step 17.
  - c. Align the padlock bracket slot with the hole in the ladder guard furthest away from the ladder rung.
  - d. Hold the padlock bracket in place and open the ladder guard and mark drill holes.

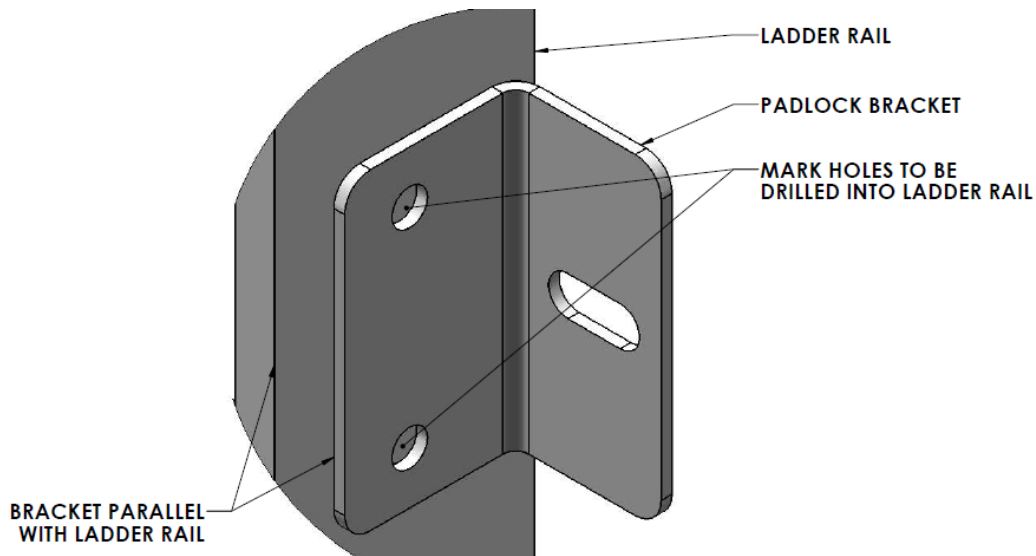

# INSTALLATION MANUAL LADDERGUARD

4064 Peavey Rd. Chaska, MN 55318  
Toll Free: 866-933-2935  
www.safetypg.com

BY: Paul Boyum  
P/N: 100389

DATE: 30 November 2016

REVISION:

C

Page 5 of 6

- e. Remove the padlock bracket and drill the padlock bracket holes.
- f. Place the hex bolts through the padlock bracket and into the ladder rail.
- g. Place the washers onto the bolts.
- h. Thread the nylock nuts onto the hex bolts and secure the padlock bracket onto the ladder rail.

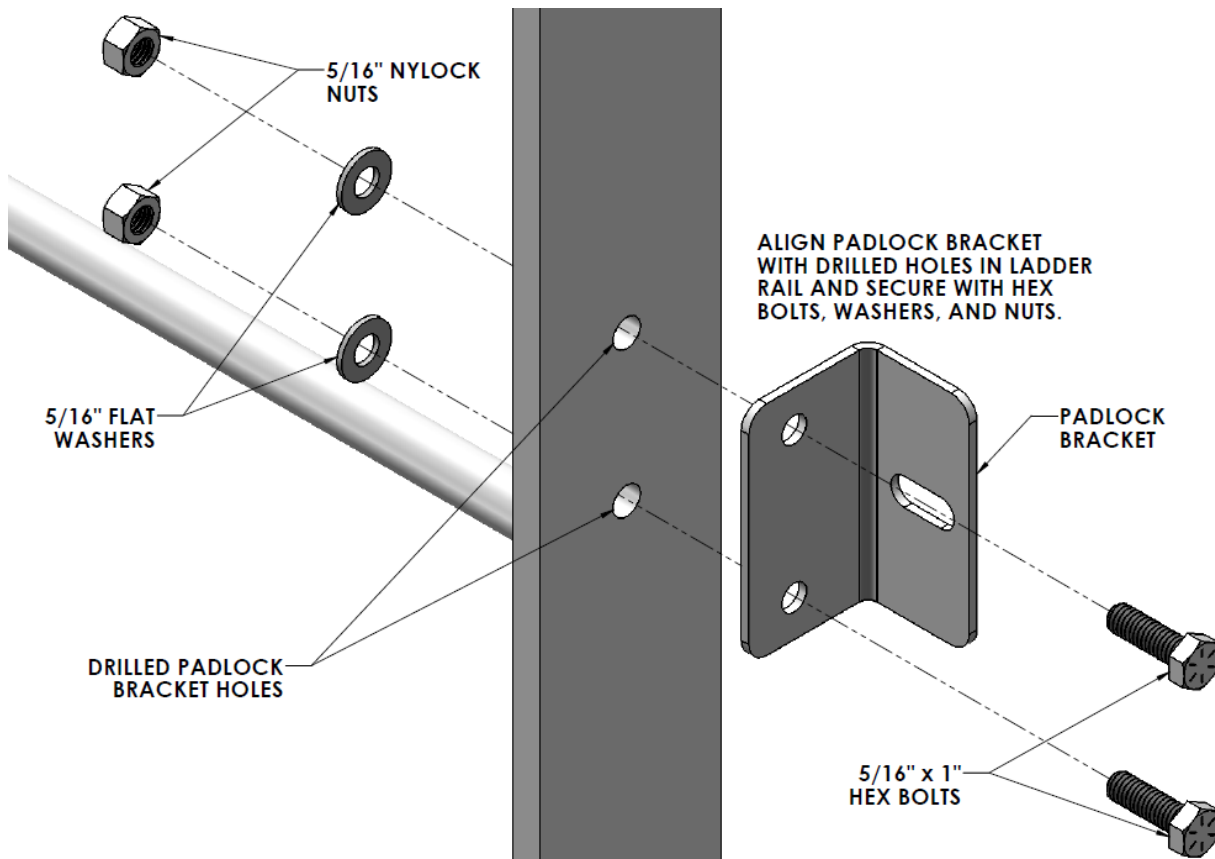

- i. Close the ladder guard and check closed alignment.
    - i. Make adjustments if necessary to ensure the padlock will smoothly pass through the ladder guard and padlock bracket.
17. For ladders with a large space between the ladder and the Ladderguard:
- a. Align the padlock bracket slot with the hole in the ladder guard furthest away from the ladder rung.
  - b. Hold the padlock bracket in place and open the ladder guard and mark the drill holes.
  - c. Remove the padlock bracket and drill the padlock bracket holes.
  - d. Place the hex bolts through the padlock bracket and bracket spacer into the ladder rail.
  - e. Place the washers onto the bolts.
  - f. Thread the nylock nuts onto the hex bolts and secure the padlock bracket onto the ladder rail.

# INSTALLATION MANUAL LADDERGUARD

4064 Peavey Rd. Chaska, MN 55318  
Toll Free: 866-933-2935  
www.safetypg.com

BY: Paul Boyum  
P/N: 100389

DATE: 30 November 2016

REVISION:

C

Page 6 of 6

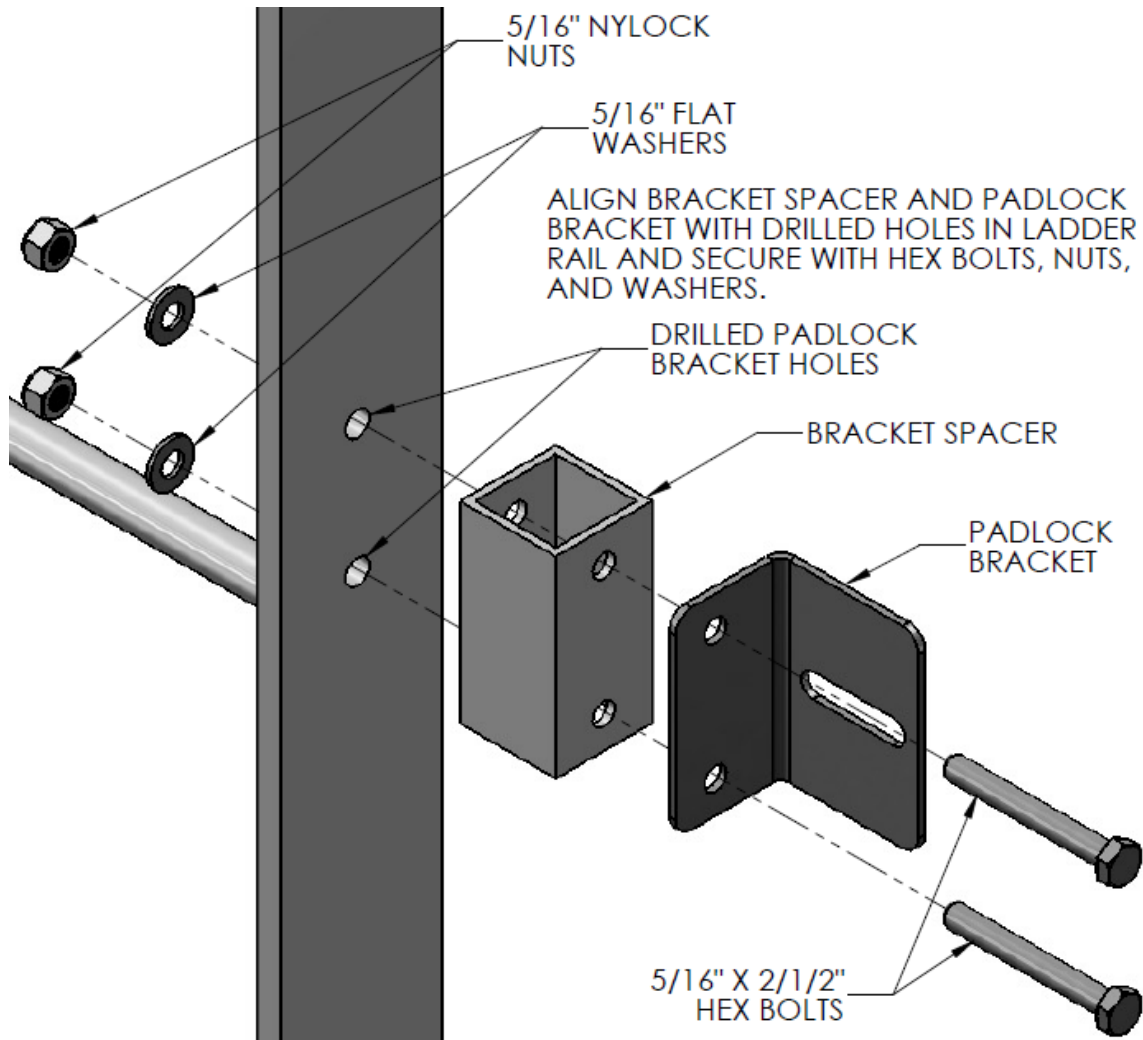

- g. Close the ladder guard and check closed alignment.
  - i. Make adjustments if necessary to ensure the padlock will smoothly pass through the ladder guard and padlock bracket.

## ANNUAL INSPECTION PROCEDURE

- CHECK FOR ANY LOOSE OR MISSING FASTENERS. TIGHTEN OR REPLACE AS NECESSARY.
  - IF DOOR GUARD IS BENT OR DAMAGED, REPLACE.